

❑ **3351.528**

1.28 gpf Exposed Top Spud Bowl
and Selectronic® Flush Valve

SYSTEM:

- Hydraulically matched to deliver a consistent powerful flush, ensuring a cleaner bowl
- Rapid installation with pre-assembled flush valve, reducing labor time and complexity during installation
- USMCA & TAA Certified
- Single Source Support for all technical and warranty needs
- 5-Year warranty

BOWL:

- High Efficiency. Operates in the range of 1.1 gpf to 1.6 gpf (4.2 Lpf to 6.0 Lpf)
- Permanent EverClean® surface
- Powerful direct-fed siphon jet action
- 1-1/2" inlet spud
- Fully-glazed 2-1/8" trapway
- 10" x 12" water surface area
- Bolt caps and seat not included
- Model 3351.101

SELECTRONIC® FLUSH VALVE:

- Factory-Installed CR-P2 Lithium Battery
- Self-Cleaning Piston reduces clogging and maintenance
- State-of-the-Art Electronics prevent ghost flushing
- Dezincification Resistant semi-red brass alloy
- Fully Mechanical Manual Override Button can flush the valve without power
- Sensor range can be adjusted manually or with optional remote control
- Adjustable Tailpiece for rough-in flexibility
- Versatility: Can be installed left or right handed
- Model 6065.121

Includes:

- 047007-0070A Inlet Spud (furnished with bowl)
- 1" I.P.S. angle stop with back-flow protection and vandal resistant cap
- 1" Sweat solder kit including cover tube and wall flange
- 1-1/2" High back pressure vacuum breaker, spud coupling and flange



SEE REVERSE FOR ROUGHING-IN DIMENSIONS

High-Efficiency Toilet Systems:

- 20% water savings when compared to a 1.6 gpf toilet system

System MaP* Score:

- 1,000 grams of miso @ 1.28 gpf

* Maximum Performance (MaP) testing performed by IAPMO R&T Lab.

BATTERY LIFE:

- 5 years @ 4,000 flushes per month

Operating Pressure:

25 psi (flowing) - 80 psi (static)

Flow Requirement:

25gpm (94.6 L/min.)

Nominal Fixture Dimensions:

660 x 356 x 381mm (26" x 14" x 15")

To Be Specified:

- ❑ Color: ❑ White
- ❑ Seat:
 - ❑ American Standard #5901.100 Heavy duty open front less cover
 - ❑ American Standard #5905.100 Extra heavy duty open front less cover



5-YEAR LIMITED
WARRANTY on
FIXTURE and
FLUSH VALVE



EVERCLEAN



EPA
WATERSENSE
CERTIFIED

**Fixture Compliance Certifications -
Meets or Exceeds the Following
Specifications:**

- ASME A112.19.2 / CSA B45.1
for Vitreous China Fixtures

Valve Listings:

- ASSE 1037/ASME A112.1037/CSA B125.37
- ADA Compliant

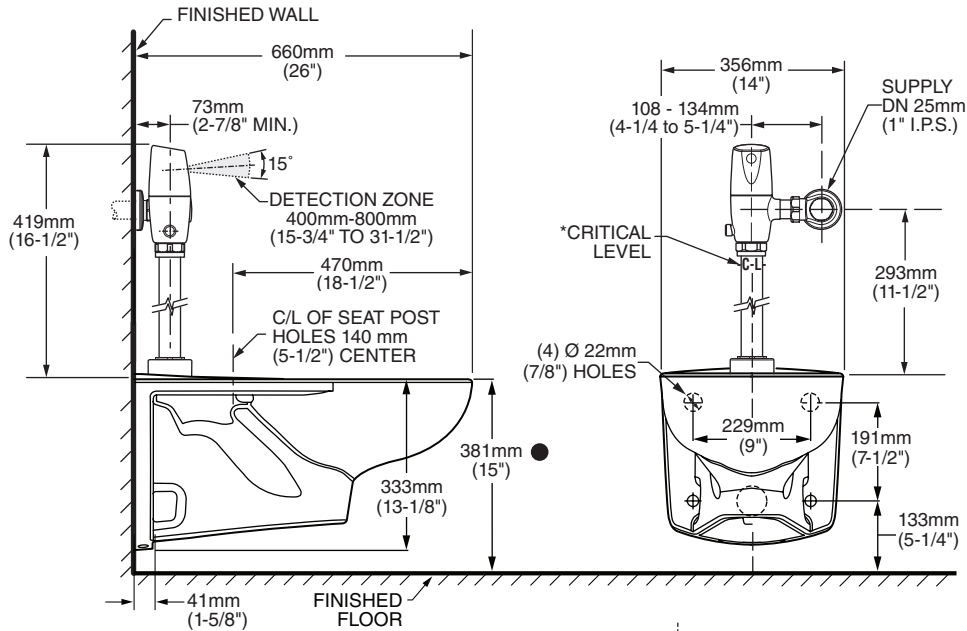

*Note: The Critical Line (-C-L-) on Vacuum Breaker must typically be a minimum of 6" (152mm) above fixture. Consult Codes for details.

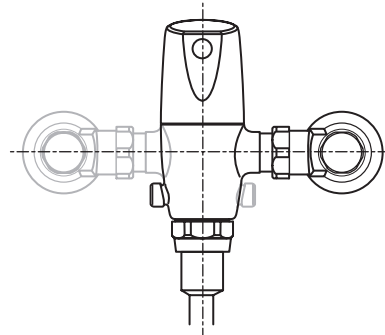

VALVE LEFT or RIGHT HAND INSTALLATION



**MEETS THE AMERICANS WITH DISABILITIES ACT GUIDELINES
AND ANSI A117.1 ACCESSIBLE AND USABLE BUILDINGS AND
FACILITIES - CHECK LOCAL CODES.**

- When installed so that top of seat is 432 to 483mm (17" to 19") from the finished floor.

NOTES:

WASTE OUTLET SEAL RING MUST BE NEOPRENE OR GRAPHITE-FELT (WAX RING NOT RECOMMENDED).

SUGGESTED 2mm (1/16) CLEARANCE BETWEEN FACE OF WALL AND BACK OF BOWL. TO COMPLY WITH AREA CODE GOVERNING THE HEIGHT OF VACUUM BREAKER ON THE FLUSHOMETER VALVE, THE PLUMBER MUST VERIFY DIMENSIONS SHOWN FOR SUPPLY ROUGHING.

CARRIER FITTING AS REQUIRED TO BE FURNISHED BY OTHERS.
PROVIDE SUITABLE REINFORCEMENT FOR ALL WALL SUPPORT.

IMPORTANT: Dimensions of fixtures are nominal and may vary within the range of tolerances established by ANSI Standard A112.19.2.

These measurements are subject to change or cancellation. No responsibility is assumed for use of superseded or voided pages